

**IEC REFERENCE
IMPEDANCE NETWORK**

Voltech Instruments Inc.

11637 Kelly Rd., Suite 306
Fort Myers, FL 33908
USA

Tel: +1 239 437 0494
Fax: +1 239 437 3841
sales@voltech.com

Voltech Instruments Ltd.

148 Harwell Business Centre
Didcot, Oxfordshire OX11 0RA
UK

Tel: +44 (0) 1235 834555
Fax: +44 (0) 1235 835016
sales@voltech.co.uk

HEALTH AND SAFETY AT WORK

Electrical devices can constitute a safety hazard. It is the responsibility of the user to ensure the compliance of the installation with any local acts or bylaws in force. Only qualified personnel should install this equipment, after reading and understanding this users guide. These operating instructions should be adhered to. If in any doubt, consult your supplier.



DANGER OF ELECTRIC SHOCK

Only qualified personnel should install this equipment, after reading and understanding this user manual. If in doubt, consult your supplier.



RISQUE D'ELECTROCUTION

L'installation de cet équipement ne doit être confiée qu'à un personnel qualifié ayant lu et compris le présent manuel d'utilisation. Dans le doute, s'adresser au fournisseur.



GEFAHR VON ELEKTRISCHEM SCHOCK

Nur entsprechend ausgebildetes Personal ist berechtigt, diese Ausrüstung nach dem Lesen und Verständnis dieses Anwendungshandbuches zu installieren. Falls Sie Zweifel haben sollten, wenden Sie sich bitte an Ihren Lieferanten.



RISCHIO DI SCARICHE ELETTRICHE

Solo personale qualificato può installare questo strumento, dopo la lettura e la comprensione di questo manuale. Se esistono dubbi consultate il vostro rivenditore.

SAFETY PRECAUTIONS

- 1) The IEC Reference Impedance Network is constructed in compliance with the requirements of EN61010-1 and as such ensures the safety of the network and the user when normal precautions are followed.
- 2) The power source should be inserted in a socket with a protective ground contact.
- 3) The power source should be inserted before connections are made to measuring or control circuits.
- 4) This instrument must only be serviced by qualified personnel who understand the danger of shock hazards.
- 5) Remove all connections before removing any covers.
- 6) The electronic circuitry of this instrument is fully floating with respect to ground. If the instrument is opened and dangerous voltages (above 50V peak) applied to the input terminals then all the circuitry must be considered 'Live'.
- 7) The signal leads must be in good condition with no damage.

IMPORTANT NOTE for users of the IEC Reference Impedance Network (USA).

The USA version of the impedance network is fitted with a standard USA 3-pin wall outlet. For convenience, and for testing at 230V ac, Voltech has rated this outlet at up to 1000V to ground. To use this socket at 230V, a suitably rated plug and line cord must be used or extra safety precautions taken. Standard line cord assemblies may not have sufficient voltage rating and may be hazardous.

EQUIPMENT CHECKLIST

The following items comprise a complete instrument:

- 1 x Impedance Override Link.
- 2 x Red test lead. Stackable 4mm safety plugs. 370mm long.
- 2 x Black test lead. Stackable 4mm safety plugs. 370mm long.
- 1 x Red test lead. 4mm safety plug to bare wire. 750mm long.
- 1 x Black test lead. 4mm safety plug to bare wire. 750mm long.
- 1 x Green / Yellow test lead. Crimp ring to bare wire 750 mm long.
- 1 x Power lead.

SPECIFICATION (Including Test Leads)

Series Resistance 50Hz, 23°C ± 8°C	0.4 +0 – 0.02Ω
Series Reactance 50Hz, 23°C ± 8°C	0.25 ± 0.01Ω
Continuous Current	16A rms
Peak Current	±50A peak
Max Voltage	±1000V peak
Operating Temperature Range	5 to 40°C
Relative Humidity	10-80% RH non-condensing
Dielectric Strength: Input to Case	2kV DC, 1 minute.
Power Source	110-220V ±20% 45-65Hz Fuse 20mm 0.5AT 10W, 20VA max

OPERATION

The Impedance Network is designed to allow full compliance testing to EN61000-3-3 (voltage fluctuations) for single-phase loads. The internal resistance and inductance provide the required source impedance when used with the supplied test leads, connected as shown in the wiring diagram to a 50Hz source with an output impedance of $<0.01\Omega$ (i.e. better than 0.2V regulation at 20A).

IMPORTANT NOTE: The Impedance Override Link must be removed when testing to EN61000-3-3. The link should be fitted when testing to EN61000-3-2 (EN60555-2) (harmonics). No other connection changes need be made.

Full details of testing to the above standards may be found in the Voltech IEC Software User Manual and Software help system. See www.voltech.com

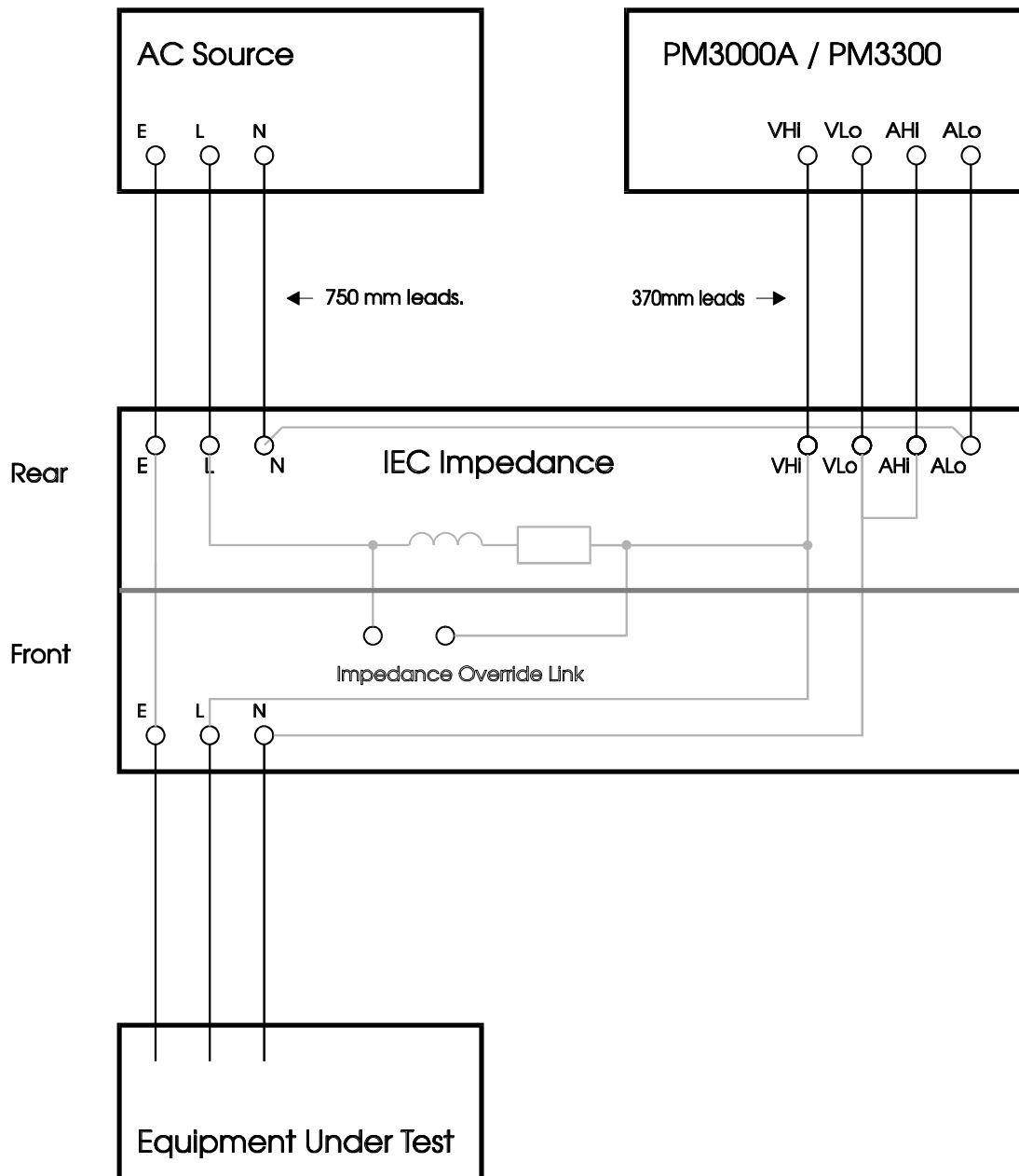

Wiring Diagram for IEC555 Testing

EN61000-3-3 (Flicker)... Impedance required ... NO link

EN61000-3-2 (Harmonics) ... No impedance ... FIT link

WARRANTY

This product is warranted against defect in materials and workmanship for a period of one year from date of shipment. During warranty period, Voltech Instruments will, at its option, either repair or replace products which prove to be defective.

For repair services under warranty, the instrument must be returned to a service centre designated by Voltech. Purchaser shall pre-pay shipment charges to service centre and Voltech will pay shipment charges to return instrument to purchaser.

Limitation of Warranty

The foregoing warranty shall not apply to defects resulting from unauthorized modification or misuse, or operation outside specification of instrument. No other warranty is expressed or implied.

Whilst every care has been taken in compiling the information in this publication Voltech Instruments Ltd cannot accept legal liability for any inaccuracies contained herein. Voltech Instruments Ltd has an intensive programme of design and development which may well alter product specification, and reserve the right to alter specification without notice and whenever necessary to ensure optimum performance from its product range.

All rights reserved.

No part of this publication may be produced, stored in a retrieval system, or transmitted in any form, or by means, electronic, mechanical photocopying, recording or otherwise without prior permission of Voltech Instruments Ltd.

DECLARATION OF CONFORMITY

Manufacturer's Name Voltech Instruments Ltd

Manufacturer's Address 65 Milton Park
Abingdon, Oxon
United Kingdom

declares, that the product

Product Name: Impedance Network

Model Number: IEC555 Reference Impedance Network

Product Options: UK & European Versions

conforms to the following Product Specifications

Safety: BS EN 61010 (1993)

EMC: BS EN 50081-2 (1992)
BS EN 50082-1 (1992)

Supplementary Information: The product herewith complies with the requirements of the EMC Directives 89/336/EEC and 91/31/EEC and the Low Voltage Directive 73/23/EEC

Signed for on behalf of Voltech Instruments Ltd

Martin Whitley, Quality Manager

Abingdon, United Kingdom January 29, 1996